

SOLAI INCLUSIONS

COMMON AREA & BUILDING SERVICES

Structure to Engineer's specifications

Mix of facebrick, metal cladding, FC sheeting, pre-cast concrete and other finishes to Architect's detail design

Slab and footings to Engineer's specifications

Metal roofing

Common areas landscaped as per landscaping design, plant species and pot sizes may be substituted due to availability

1 lockable letterbox per unit provided

Common areas and car parking levels as required by the NCC. Sprinklers to NCC requirements. Detection system to residential apartments comprising smoke alarms and sound alert system as required by the NCC and the ACT Fire Brigade.

Waste management is the responsibility of Body Corporate

GENERAL INCLUSIONS

90 day maintenance period

Double Glazed Aluminium windows and sliding doors with fly screens as per EER to all Types

Ducted reverse cycle air-conditioning to all townhouses

Wall mounted reverse cycle air-conditioning to a living and master bedroom to all apartment Types

Pre-wired for NBN fit-off and connections

Electric instantaneous hot water

LED down lighting throughout all rooms - unless stated otherwise

Plasterboard walls and ceilings throughout all rooms - unless stated otherwise

Townhouses: Generally 2550mm to lower level and 2400mm on the upper levels. (E Type 2500 kitchen entry with 3270 to kitchen, living and dining). Apartments: Generally 2400mm. Ceiling heights are subject to Architect's detail design for all plan types. Bulkheads, wet areas and bathroom heights subject to detail design.

Water and sewerage supply to each unit by Icon Water

GENERAL INCLUSIONS CONT.

Body Corporate Sub-Metering

Electrical meters will be installed and connected

Visitor parking provided as per site plan

Each unit will be provided with 2 x front door keys

Applicable dwellings with designated carparking within the basement will be provided with remotes for carpark entry

Common walls and party walls to NCC requirements

KITCHEN

2 x LED Downlights

Timber-look flooring as per Colour Selection

2 x Double GPO and all appliances as required

20mm quartz benchtops as per Colour Selection

Melamine joinery - as per Colour Selection and detailed design

Clarke Prism 1.5 Bowl Sink

Caroma Pull Out Sink Mixer

Franke 600mm Oven

Franke 600mm Induction Cooktop

Franke 600mm Freestanding Dishwasher

Franke Urban 520mm Undermount Rangehood

LIVING & DINING

4 x LED Downlights

2 x Double GPO

1 x TV point

1 x Data point

Timber-look flooring as per Colour Selection

SOLAI INCLUSIONS

MULTI-PURPOSE ROOM / RUMPUS (WHERE APPLICABLE)

2 x LED Downlights

1 x Double GPO

1 x Data Point

Carpet as per Colour Selection (Type B ground floor timber-look flooring as per selection)

MASTER BEDROOM

2 x LED Downlights

3 x Double GPO

1 x TV point

1 x Data point

Carpet as per Colour Selection

Built in Robe with Mirrored Sliding Doors or Walk in Robe subject to specific Unit Plan Type in accordance with Architect's detailed design and spacial requirements

BEDROOM 2 & 3 (WHERE APPLICABLE)

2 x LED Downlights

2 x Double GPO

Carpet as per Colour Selection

Built in Robe with Mirrored Sliding Doors subject to specific Unit Plan Type in accordance with Architect's detail design

BATHROOM & ENSUITE (WHERE APPLICABLE)

2 x LED Downlights

1 x Double GPO

Mechanical ventilation as per NCC requirements

Tiles as per Colour Selection

Full height tiling to Architect's detail as per Colour Selection

Clark Back To Wall Toilet Suite

Wall hung vanity unit size to suit bathroom specification

BATHROOM & ENSUITE CONT.

Mirror as per Architect's detail design

Clark Basin Mixer

Clark Pin Wall Mixer

Clark Wall Shower Head & Arm

Clark Toilet Roll Holder

Clark Towel Rail size to suit bathroom specification

Clark Robe Hook

Semi-frameless or framed glass shower screen to meet Architect's detail design

TOILET / POWDER ROOM (WHERE APPLICABLE)

1 x LED Downlight

Mechanical ventilation as per NCC requirements

Tiles as per Colour Selection

One row skirting tiles as per Colour Selection

Clark Back To Wall Toilet Suite

Wall hung vanity unit to suit bathroom specification

Mirror as per Architect's detail design

Clark Basin Mixer

Clark Toilet Roll Holder

LAUNDRY

1 x light if required to comply with NCC requirements

1 x Double GPO

Mechanical ventilation as per NCC requirements

Tiles as per Colour Selection

One row skirting tiles as per Colour Selection

Washing machine hot and cold water connections

Stainless steel tub and cabinet or laundry tub sink subject to Architect's detail design and spatial requirements

Stylus Verdi Sink Mixer

SOLAI INCLUSIONS

GARAGE (WHERE APPLICABLE)

Colorbond roller door

1 x remote for single garage, 2 x remote for double garage

LED or fluorescent lighting as required

1 x Double GPO 15 amp Output

COURTYARD / BALCONY

External outdoor light

All common areas to be landscaped as per design, all private courtyards to be left generally level. Balcony finish subject to Architect's detail design and landscape intention plan

External courtyard tap for townhouses (where applicable)

ADDITIONAL NOTES

The buyer will have the choice of 2 colour schemes to select from. If the buyer does not make a selection on exchange of the Contract Date, the Seller may make the selection on the Buyer's behalf.

Buyers agree and acknowledge that the finishes proposed for use in the units may include materials such as reconstituted stone and timber-look laminate flooring. These materials may display characteristics which vary from the samples shown to the Buyer at any time due to the nature of such materials.

Items listed in this document refer to Architectural detail design. Minor variations in location and quantities of these items may occur following the architectural detail design.

The Seller reserves the right to substitute any specified inclusions with that of a similar quality.

QUALITY, ENERGY EFFICIENT FIXTURES & FITTINGS COME AS STANDARD

Enjoy high-end European appliances from Franke, and elevated fittings from Clark and Caroma in brushed nickel from day one.

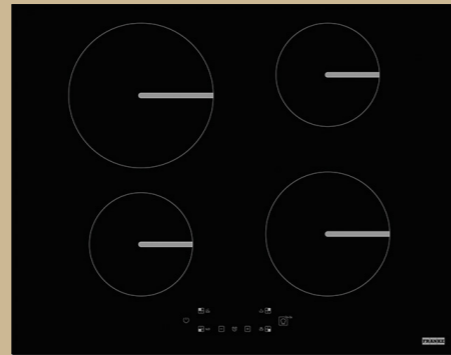

1

2

3

4

5

6

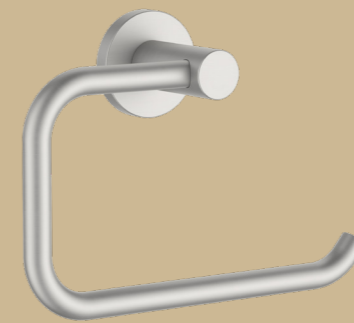
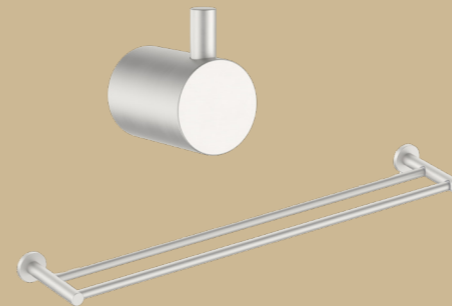

7

8

9

10

11

12

- 1 Franke Dishwasher 2 Franke Built-In Oven 3 Franke Induction Cooktop 4 Franke Ducted Rangehood 5 Clark Prism 1.5 Bowl Square-Set Sink 6 Caroma Pull-Out Sink Mixer
7 Clark Rain Shower Head & Arm 8 Clark Shower Wall Mixer 9 Clark Basin Mixer 10 Clark Robe Hooks & Towel Rails 11 Clark Toilet Roll Holder 12 Clark Back to Wall Toilet Suite